

BioMedical Admissions Test

Specimen

40 minutes

SECTION 2

Scientific Knowledge and Applications

INSTRUCTIONS TO CANDIDATES

Please read this page carefully, but do not open the question paper until you are told that you may do so.

This paper is Section 2 of 3. Your supervisor will collect this question paper and answer sheet before giving out Section 3.

A separate answer sheet is provided for this section. Please check you have one. You also require a soft pencil and an eraser.

A separate glossary sheet contains Dutch translations of some of the technical terms used in this section. Please check you have one.

Please complete the answer sheet with your:

- BMAT candidate number
- Centre number
- Date of birth
- Name

Speed as well as accuracy is important in this section. **Work quickly, or you may not finish the paper.** There are no penalties for incorrect responses, only marks for correct answers, so you should attempt all 27 questions. Each question is worth one mark.

Answer on the sheet provided. Questions ask you to show your choice between options by shading one circle. If you make a mistake, erase thoroughly and try again.

You **must** complete the answer sheet within the time limit.

You can use the question paper for rough working or notes, but **no extra paper** is allowed.

Calculators are NOT permitted.

Please wait to be told you may begin before turning this page.

This paper consists of 18 printed pages and 2 blank pages.

BLANK PAGE

- 1 The diagram below shows part of the nitrogen cycle.

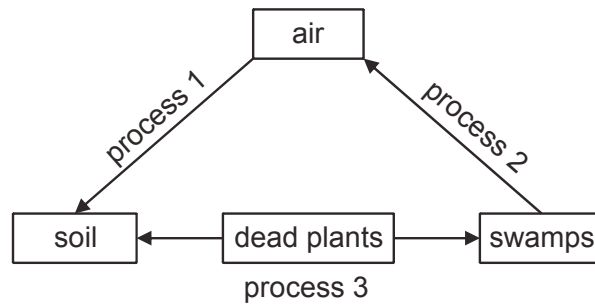

Which row of the table correctly identifies processes 1, 2 and 3?

| | <i>process 1</i> | <i>process 2</i> | <i>process 3</i> |
|----------|-------------------|-------------------|-------------------|
| A | decomposition | nitrification | nitrogen fixation |
| B | decomposition | nitrogen fixation | nitrification |
| C | denitrification | nitrification | nitrogen fixation |
| D | denitrification | nitrogen fixation | decomposition |
| E | nitrification | decomposition | denitrification |
| F | nitrification | denitrification | decomposition |
| G | nitrogen fixation | decomposition | denitrification |
| H | nitrogen fixation | denitrification | decomposition |

2 Which of the following could possibly take part in an addition polymerisation reaction?

- 1 CHI_3
- 2 $\text{C}_{24}\text{H}_{48}$
- 3 $\text{C}_3\text{H}_7\text{Br}$
- 4 $\text{C}_4\text{H}_6\text{Cl}_2$
- 5 $\text{C}_8\text{H}_{12}\text{Cl}_4$

- A 1, 2 and 3 only
- B 1, 2 and 4 only
- C 1, 3 and 5 only
- D 2, 3 and 4 only
- E 2, 4 and 5 only
- F 3, 4 and 5 only

3 After running a marathon, a particular runner wraps herself in a thin aluminium-covered plastic sheet in order to keep warm.

Here are some suggested statements about the effects this may have on heat loss from her body:

- 1 There is less heat loss through conduction, because aluminium is a good conductor of heat.
- 2 There is less heat loss through convection, because air is trapped between the sheet and the body.
- 3 There is less heat loss through radiation, because shiny metal surfaces are poor emitters of thermal radiation.

Which of these statements is/are correct?

- A 1 only
- B 2 only
- C 3 only
- D 1 and 2 only
- E 1 and 3 only
- F 2 and 3 only
- G 1, 2 and 3
- H none of them

- 4 The right-angled triangle shown has horizontal and vertical sides measuring $(4 + \sqrt{2})$ cm and $(2 - \sqrt{2})$ cm, respectively.

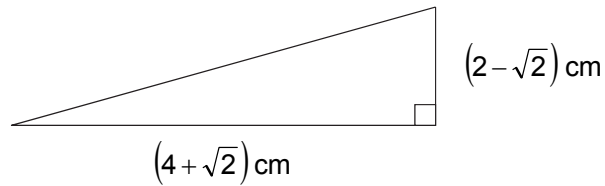

Calculate the area of the triangle.

- A $(3 - 3\sqrt{2})$ cm²
 B $(3 + 3\sqrt{2})$ cm²
 C $(3 - \sqrt{2})$ cm²
 D $(5 - \sqrt{2})$ cm²
 E $(5 - 3\sqrt{2})$ cm²
 F $(5 + 3\sqrt{2})$ cm²
- 5 The SAN pacemaker is found in the wall of one of the four chambers of the human heart.
- Which row correctly identifies the chamber with the SAN pacemaker present and the blood found in the lumen (cavity) of that chamber?

| | <i>chamber with SAN present</i> | <i>blood found in the lumen</i> |
|----------|---------------------------------|---------------------------------|
| A | left atrium | oxygenated |
| B | right atrium | oxygenated |
| C | left ventricle | oxygenated |
| D | right ventricle | oxygenated |
| E | left atrium | deoxygenated |
| F | right atrium | deoxygenated |
| G | left ventricle | deoxygenated |
| H | right ventricle | deoxygenated |

- 6 Inorganic substances are put into detergents to act as a buffer, i.e. to keep the pH close to 7. Sodium tripolyphosphate is one major one that is used. The equation for its formation is shown below:

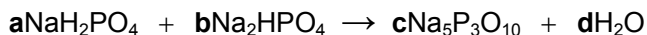

What are the values of **a**, **b**, **c** and **d**, respectively?

- A** 3, 1, 1, 3
B 6, 2, 2, 7
C 2, 4, 2, 2
D 1, 2, 1, 2
E 2, 2, 1, 2
- 7 Two identical cars, P and Q, start at the same level. Car P moves at a constant speed of 10 m/s up a hill to a height of 25 m in a time of 20 s. In the same time, car Q moves at a constant speed of 20 m/s up a hill to a height of 50 m.

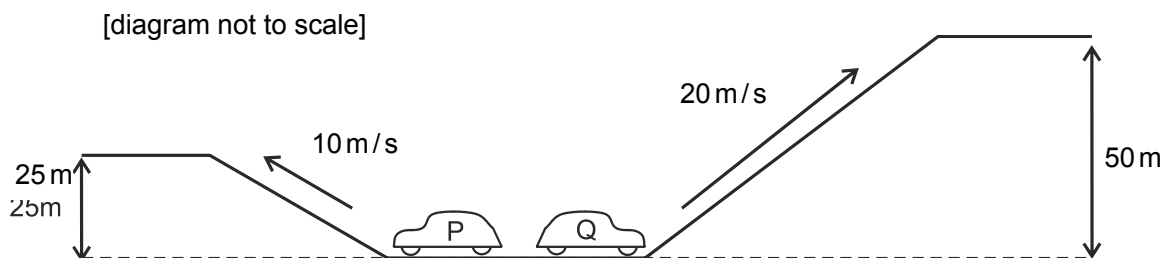

Which of the following statements are correct for the kinetic energies of the cars while they are travelling up the hills, and for their gravitational potential energies once they are at the top?

| | <i>kinetic energy</i> | <i>gravitational potential energy</i> |
|----------|---------------------------------------|---------------------------------------|
| A | car Q has twice as much as car P | car Q has twice as much as car P |
| B | car Q has twice as much as car P | car Q has four times as much as car P |
| C | car Q has four times as much as car P | car Q has twice as much as car P |
| D | car Q has four times as much as car P | car Q has four times as much as car P |

8 Simplify:

$$\left(\frac{2x^{\frac{3}{2}}y^3}{\sqrt{z}} \right)^2$$

A $\frac{4x^6y^5}{z^2}$

B $\frac{4x^3y^6}{z}$

C $\frac{4x^3y^5}{z}$

D $\frac{4x^{\frac{5}{2}}y^5}{z}$

E $\frac{4x^{\frac{5}{2}}y^5}{z^2}$

- 9 Individual P in the family pedigree below is homozygous dominant and individual Q is homozygous recessive for a particular feature.

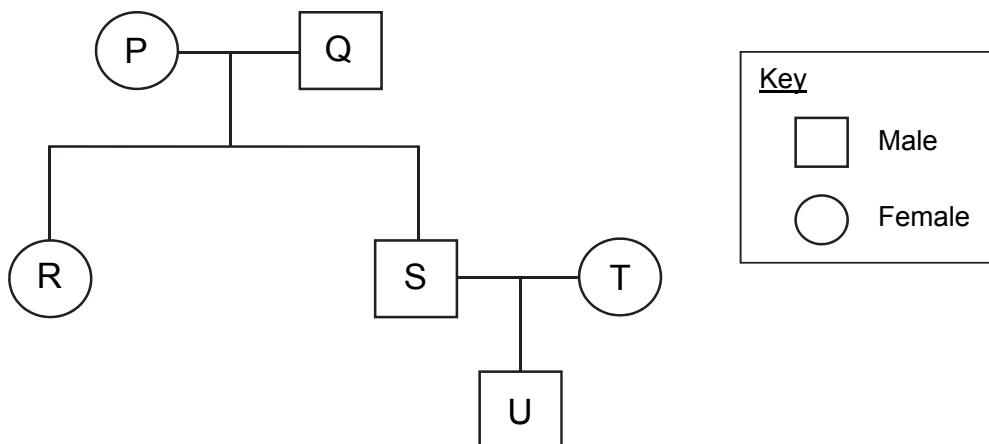

What is the percentage probability that individual U is homozygous recessive if:

| | <i>i) T is homozygous recessive</i> | <i>ii) T is heterozygous</i> |
|----------|-------------------------------------|------------------------------|
| A | 50% | 0% |
| B | 25% | 50% |
| C | 50% | 25% |
| D | 25% | 0% |
| E | 0% | 25% |

- 10 The reaction between nitrogen and hydrogen to form ammonia is exothermic.



The bond energies in the three molecules are as shown.

| | |
|----------------------------|--------------------|
| $\text{N} \equiv \text{N}$ | $x \text{ kJ/mol}$ |
| $\text{H} - \text{H}$ | $y \text{ kJ/mol}$ |
| $\text{N} - \text{H}$ | $z \text{ kJ/mol}$ |

Which statement can be deduced from this information?

- A** $z > x + y$
B $2z > x + y$
C $2z > x + 3y$
D $6z > x + 3y$

- 11 A parachutist falls from an aircraft and reaches a terminal velocity. After a while, he opens his parachute and reaches a new (lower) terminal velocity.

Which graph shows how the total air resistance (drag) force acting on him and his parachute varies with time during the fall?

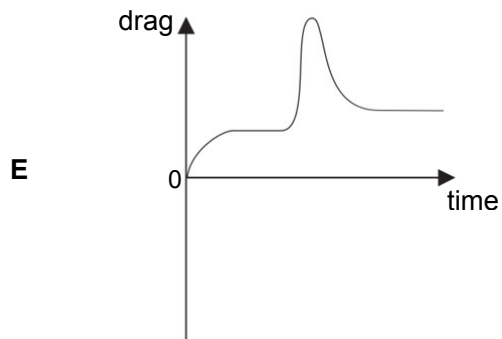
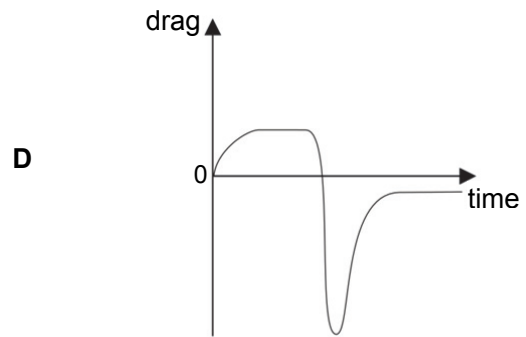
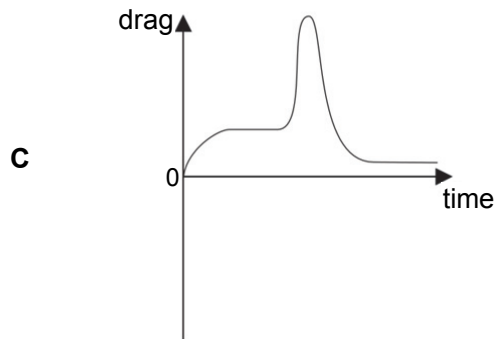
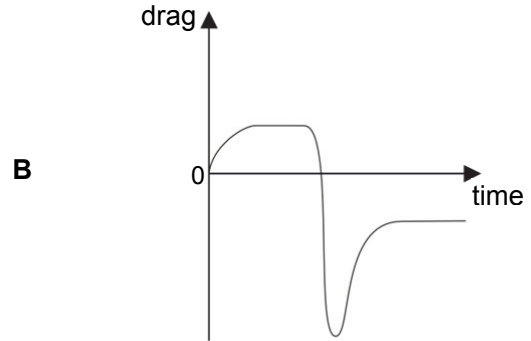
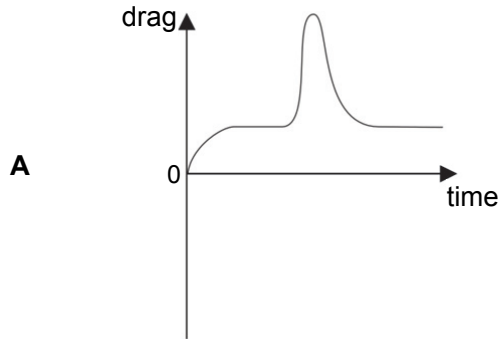

- 12 A bag contains x red balls, y blue balls and z yellow balls. One ball at random is taken out and put back. A second ball at random is taken out and put back.

If the balls are identical in all respects except colour and are well mixed, what is the probability that the first ball was red and the second blue?

A $\frac{(x+y)}{(x+y+z)}$

B $\frac{(x+y)}{(x+y+z)^2}$

C $\frac{xy}{(y+z)(x+z)}$

D $\frac{xy}{(x+y+z)(x+z)}$

E $\frac{xy}{(x+y+z)^2}$

- 13 Signals travelling along a reflex arc pass from one neuron to the next neuron by the release of transmitter molecules. The statements below are about this process.

- 1 The signal is transmitted across the synapse by osmosis.
- 2 Transmitter molecules are released once the signal has been transmitted across the synapse.
- 3 The release of transmitter molecules is triggered by the signal.
- 4 The signal is transmitted across the synapse by diffusion.

Which of the above statements are correct?

- A 1 and 2 only
- B 1 and 3 only
- C 1 and 4 only
- D 2 and 4 only
- E 3 and 4 only

14 Hydrogen, magnesium and phosphate can exist as the following ions: H^+ , Mg^{2+} , PO_4^{3-} . Different salts can be formed from these ions. Which formula below is a formula for one of these salts?

- A $\text{Mg}(\text{HPO}_4)_2$
- B $\text{Mg}(\text{H}_2\text{PO}_4)_2$
- C MgH_3PO_4
- D $\text{Mg}(\text{H}_3\text{PO}_4)_2$
- E Mg_2HPO_4
- F $\text{Mg}_2\text{H}_2\text{PO}_4$

15 Two radioactive sources X and Y have half-lives of 4.8 hours and 8.0 hours, respectively. Both decay directly to form only stable isotopes.

The activity of a sample of the source X is measured by a detector as 320 counts per minute, and simultaneously the radioactivity of a sample of the source Y is measured as 480 counts per minute. Immediately after the measurements, the two samples are combined.

What is the count rate when the activity of the combination of X and Y is measured 24 hours later?

[Assume that all readings in this question have been corrected for background radiation.]

- A 25 counts per minute
- B 50 counts per minute
- C 55 counts per minute
- D 70 counts per minute
- E 100 counts per minute
- F 140 counts per minute

16 In statistics, Spearman's rank correlation coefficient is given by the formula:

$$r = 1 - \frac{6 \sum d^2}{n(n^2 - 1)}$$

Rearrange the formula to make $\sum d^2$ the subject.

- A $\sum d^2 = 1 - \frac{r(n^3 - n)}{6}$
- B $\sum d^2 = \left(\frac{(1-r)(n^3 - n)}{6} \right)^2$
- C $\sum d^2 = \frac{(1-r)(n^3 - 1)}{6}$
- D $\sum d^2 = \frac{(1+r)(n^3 - n)}{6}$
- E $\sum d^2 = \frac{(1-r)(n^3 - n)}{6}$

17 The three statements below are about breathing out.

- 1 The ribs swing down and inwards when breathing out.
- 2 The diaphragm muscles contract when breathing out.
- 3 The pressure in the lungs increases when breathing out.

Which of these statements is/are correct?

- A 1 only
- B 2 only
- C 3 only
- D 1 and 2 only
- E 1 and 3 only
- F 2 and 3 only

18 An ore of lead contains lead only in the form of lead(II) sulfide, PbS.

By mass, 75% of this ore is PbS.

Calculate the maximum mass of lead that can be extracted from 480 kg of the ore.

[A_r: Pb = 207; S = 32]

A 48.20 kg

B 103.9 kg

C 180.0 kg

D 311.8 kg

E 415.7 kg

- 19 The depth of water in a particular tidal harbour varies with time as shown in the graph:

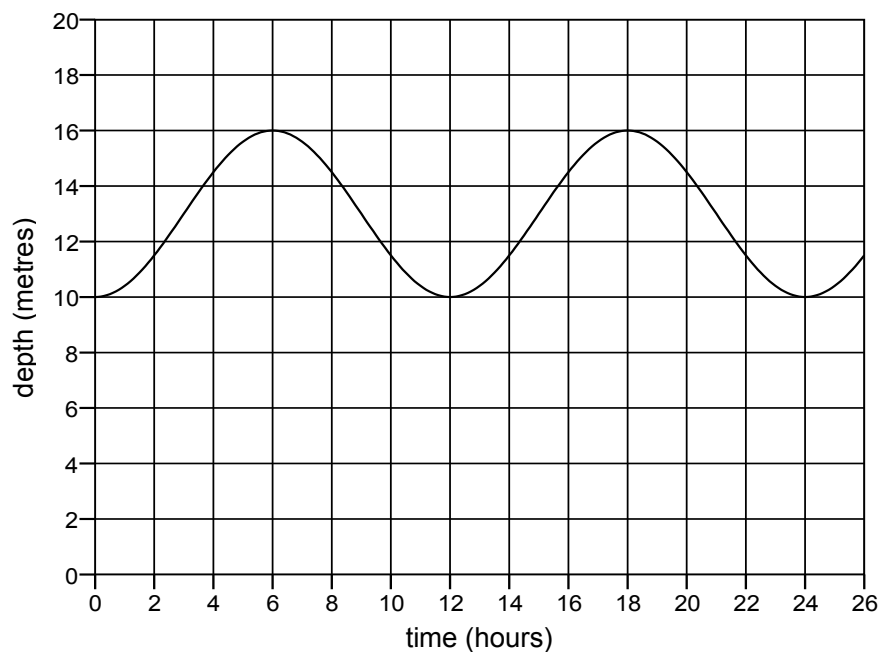

If the variation in depth caused by the effect of the tide is considered as a wave, what are the amplitude and frequency of this wave?

| | <i>amplitude (m)</i> | <i>frequency (Hz)</i> |
|----------|----------------------|----------------------------|
| A | 3 | $\frac{1}{12 \times 3600}$ |
| B | 3 | $\frac{3600}{12}$ |
| C | 6 | $\frac{1}{24 \times 3600}$ |
| D | 6 | $\frac{3600}{24}$ |
| E | 8 | $\frac{1}{12 \times 3600}$ |
| F | 8 | $\frac{3600}{12}$ |
| G | 16 | $\frac{1}{24 \times 3600}$ |
| H | 16 | $\frac{3600}{24}$ |

20 The graphs of the following equations are drawn:

1 $y = 3x - 2$

2 $y = x^2$

3 $y = 1 - x^2$

4 $y = x + 6$

Which pair of graphs do **not** intersect?

- A 1 and 2
- B 1 and 3
- C 2 and 3
- D 2 and 4
- E 3 and 4

21 The table shows the concentrations, in arbitrary units, of four substances. These substances are present in each of two animal cells, 1 and 2, whose cell membranes are in contact.

| <i>substance</i> | <i>concentration in arbitrary units</i> | |
|------------------|---|---------------|
| | <i>cell 1</i> | <i>cell 2</i> |
| P | 9 | 15 |
| Q | 12 | 8 |
| R | 7 | 4 |
| S | 6 | 3 |

Which overall movement of a substance between the two cells requires oxygen?

- A P: cell 2 → cell 1
- B Q: cell 1 → cell 2
- C R: cell 2 → cell 1
- D S: cell 1 → cell 2

- 22** Assume that element Y forms a naturally-occurring ion Y^{3-} with the electronic configuration 2,8,8.

Using this information, determine to which Group and Period of the IUPAC Periodic Table Y would belong.

| | <i>Group</i> | <i>Period</i> |
|----------|--------------|---------------|
| A | 13 | 3 |
| B | 13 | 4 |
| C | 15 | 3 |
| D | 15 | 4 |
| E | 18 | 3 |
| F | 18 | 4 |

- 23** A 100% efficient transformer has 1500 turns in its primary coil. The input to the transformer is 250 V alternating current (a.c.). The output is connected to a resistor. The output current is 10 A and the output power is 0.50 kW.

What is the number of turns in the secondary coil?

- A** 75
- B** 300
- C** 750
- D** 7500
- E** 30 000

- 24 A solid sphere of radius r fits inside a hollow cylinder. The cylinder has the same internal diameter and length as the diameter of the sphere.

The volume of a sphere is $\frac{4}{3}\pi r^3$, where r is the radius of the sphere.

What fraction of the space inside the cylinder is taken up by the sphere?

- A $\frac{1}{4}$
- B $\frac{1}{3}$
- C $\frac{1}{2}$
- D $\frac{2}{3}$
- E $\frac{3}{4}$

- 25 Which one of the following is **not** needed in order to genetically engineer bacterial cells to produce a fluorescent protein from a jellyfish?

- A a plasmid or viral vector
- B enzymes to cut DNA molecules
- C fluorescent protein from a jellyfish
- D ligase enzyme

- 26 A compound of iodine and oxygen contains 63.5g of iodine and 20.0g of oxygen.

Which of the following could be the molecular formula for this compound?

[A_r : I = 127; O = 16]

- A IO
- B IO₂
- C I₂O
- D I₂O₃
- E I₂O₅
- F I₅O₂

- 27 The microwaves generated in a microwave oven travel through air at a speed of 3.0×10^8 m/s, with a wavelength of 12 cm. They pass through plastic food containers, but at a reduced speed of 2.0×10^8 m/s.

What are the wavelength and frequency of these microwaves as they pass through a plastic food container?

| | <i>wavelength (cm)</i> | <i>frequency (Hz)</i> |
|----------|------------------------|-----------------------|
| A | 8.0 | 1.7×10^9 |
| B | 8.0 | 2.5×10^9 |
| C | 8.0 | 3.8×10^9 |
| D | 12 | 1.7×10^9 |
| E | 12 | 3.8×10^9 |
| F | 18 | 1.7×10^9 |
| G | 18 | 2.5×10^9 |
| H | 18 | 3.8×10^9 |

END OF TEST

BLANK PAGE

Cambridge Assessment Admissions Testing offers a range of tests to support selection and recruitment for higher education, professional organisations and governments around the world. Underpinned by robust and rigorous research, our assessments include:

- assessments in thinking skills
- admissions tests for medicine and healthcare
- behavioural styles assessment
- subject-specific admissions tests.
-

We are part of a not-for-profit department of the University of Cambridge.

Cambridge Assessment

Admissions Testing

1 Hills Road

Cambridge

CB1 2EU

United Kingdom

Admissions tests support:

www.admissionstestingservice.org/help